

Coromant Capto® Short Adapter

The quick change system for reduced
setup and production time.

Faster return on investment.



Short Adapter

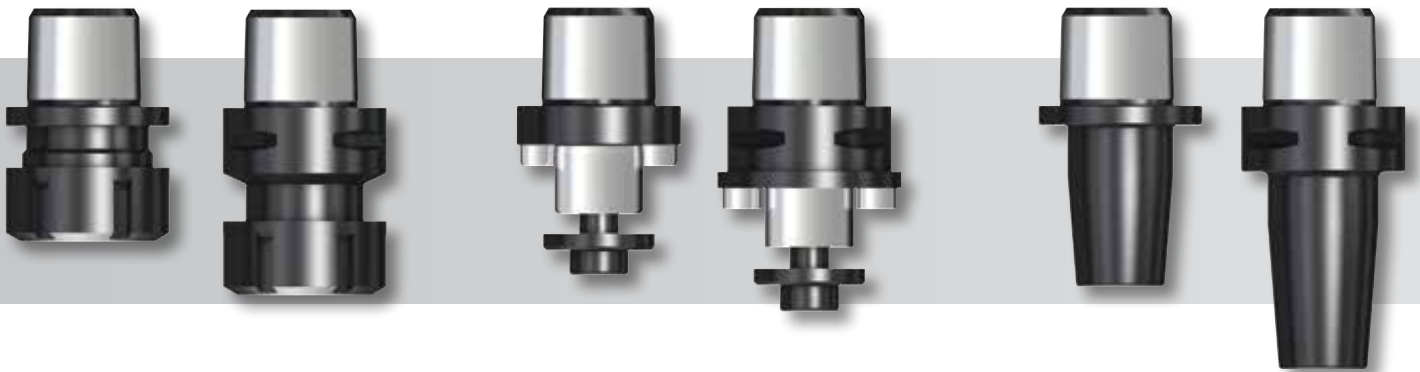

- **More available cutting tool length**

Short toolholder projection with no gripper groove

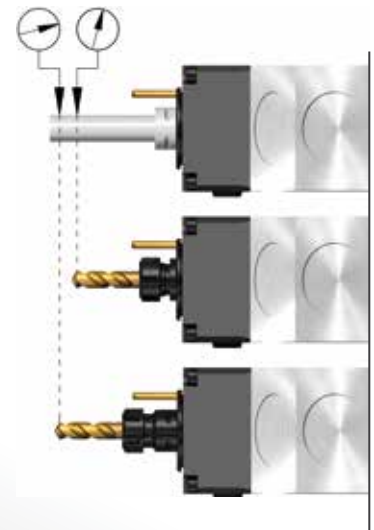

- **Higher accuracy**

Smaller run-out error through reduced projection length



Interface ISO 26623.

The short Coromant Capto® adapters are designed for driven precision toolholders providing significant advantages.



Short adapter for segment clamping only.
Cannot be used in basic holders, extensions,
or reductions.
Not for automatic tool change (ATC).

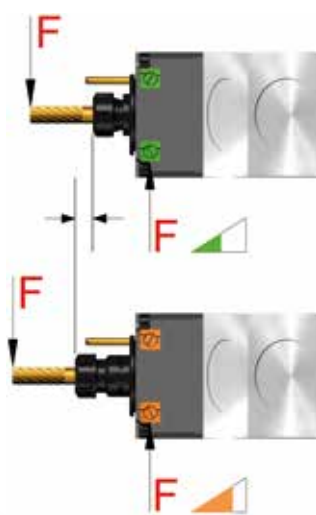

- **Higher stability**

Lower vibrations through reduced tool projection length

- **Longer lifetime**

Lower load on the bearings through shorter torsion



Short collet chuck adapter – without gripper groove

DIN 6499, ISO 15488

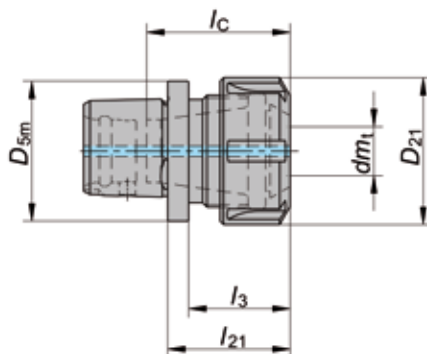

Coupling Size	Item No.	D _{5m}	dm _t min	dm _t max	D ₂₁	l _c	l ₃	l ₂₁		Nm	Collet Size		
C3	C3-W-391.14-16 030	32	0.5	10	28	32.5	24	30	0.12	56	ER 16	200016000	107516000
	C3-W-391.14-20 035	32	1	13	34	38	29	35	0.15	80	ER 20	200020000	107520000
	C3-W-391.14-25 044	40	1	16	42	41	-	44	0.25	104	ER 25	200025000	107525000
C4	C4-W-391.14-20 032	40	1	13	34	38	26	32	0.20	80	ER 20	200020000	107520000
	C4-W-391.14-25 035	40	1	16	42	41	29	35	0.25	104	ER 25	200025000	107525000
	C4-W-391.14-32 052	50	2	20	50	47	-	52	0.43	136	ER 32	200032000	107532000
C5	C5-W-391.14-25 034	50	1	16	42	41	28	34	0.35	104	ER 25	200025000	107525000
	C5-W-391.14-32 041	50	2	20	50	47	35	41	0.42	136	ER 32	200032000	107532000
	C5-W-391.14-40 058	63	3	26	63	53	-	58	0.76	176	ER 40	200040000	107540000
C6	C6-W-391.14-32 042	63	2	20	50	60	47	55	0.64	136	ER 32	200032000	107532000
	C6-W-391.14-40 048		3	26	63	53	40	48	0.79	176	ER 40	200040000	107540000

Dimensions, mm

Short hydro high precision chuck adapter – without gripper groove

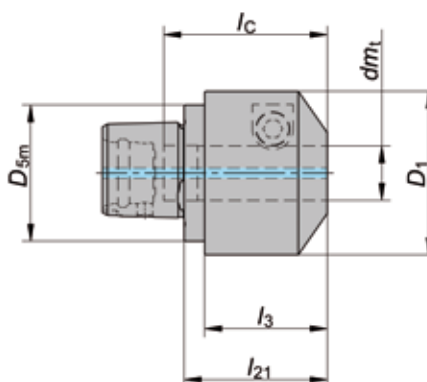

Coupling Size	Item No.	D _{5m}	d m _t	D ₁	l _c	l ₃	l ₂₁		Collet Size
C3	C3-W-391.CGC-12 042	32	12	43.5	45	36	42	0.4	12
C4	C4-W-391.CGC-16 042	40	16	48	48	36	42	0.5	16
C5	C5-W-391.CGC-20 046	50	20	52	53	40	46	0.7	20
C6	C6-W-391.CGC-25 050	63	25	59	58	44	50	1.1	25

Dimensions, mm

Note:
Without adjustment screw.
Available collets in accessories section.



Short Weldon/Whistle Notch shank adapter – without gripper groove

For tool shanks according to DIN 6535-HB and -HE

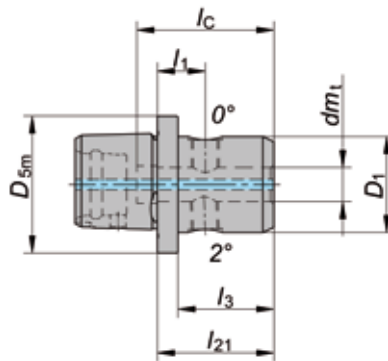

Coupling Size	Item No.	D _{5m}	dm _t	D ₁	l ₁	l _c	l ₃	l ₂₁	kg		
C3	C3-W-391.22-06 033	32	6	19	15	36	27	33	0.12	12882	26071
	C3-W-391.22-08 033	32	8	21	15	36	27	33	0.12	12927	26072
	C3-W-391.22-10 037	32	10	28	17	40	31	37	0.19	12992	26073
	C3-W-391.22-12 042	32	12	34	19.5	45	37	42	0.28	13061	26074
	C3-W-391.22-14 043	32	14	36	20.5	45	36	43	0.31	13061	26074
	C3-W-391.22-16 051	32	16	38	27	49	44	51	0.39	30944	26075
C4	C4-W-391.22-06 030	40	6	19	12	36	24	30	0.17	12882	26071
	C4-W-391.22-08 030	40	8	21	12	36	24	30	0.18	12927	26072
	C4-W-391.22-10 034	40	10	28	14	40	28	34	0.24	12992	26073
	C4-W-391.22-12 039	40	12	34	16.5	45	33	39	0.32	13061	26074
	C4-W-391.22-14 039	40	14	36	16.5	45	33	39	0.34	13061	26074
	C4-W-391.22-16 043	40	16	38	19	49	37	43	0.38	30944	26075
	C4-W-391.22-18 043	40	18	40	19	49	-	43	0.40	30944	26075
	C4-W-391.22-20 045	40	20	45	20	51	36	45	0.49	106290	26076
C5	C5-W-391.22-06 029	50	6	19	11	36	23	29	0.28	12882	26071
	C5-W-391.22-08 029	50	8	21	11	36	23	29	0.29	12927	26072
	C5-W-391.22-10 033	50	10	28	13	40	27	33	0.34	12992	26073
	C5-W-391.22-12 038	50	12	34	15.5	45	32	38	0.42	13061	26074
	C5-W-391.22-14 038	50	14	36	15.5	45	32	38	0.44	13061	26074
	C5-W-391.22-16 041	50	16	38	17	48	35	41	0.47	30944	26075
	C5-W-391.22-18 042	50	18	40	18	49	36	42	0.50	30944	26075
	C5-W-391.22-20 044	50	20	45	19	51	38	44	0.58	106290	26076
	C5-W-391.22-25 050	50	25	51	26	57	44	50	0.72	13128	26076
C6	C6-W-391.22-06 030	63	6	19	12	36	22	30	0.51	12882	26071
	C6-W-391.22-08 031	63	8	21	13	36	23	31	0.52	12927	26072
	C6-W-391.22-10 034	63	10	28	14	40	26	34	0.57	12992	26073
	C6-W-391.22-12 037	63	12	34	14.5	45	29	37	0.63	13061	26074
	C6-W-391.22-14 037	63	14	36	14.5	45	29	37	0.64	13061	26074
	C6-W-391.22-16 041	63	16	38	17	49	33	41	0.69	30944	26075
	C6-W-391.22-18 041	63	18	40	17	49	33	41	0.70	30944	26075
	C6-W-391.22-20 043	63	20	45	18	51	35	43	0.77	106290	26076
	C6-W-391.22-25 050	63	25	51	26	57	42	50	0.92	13128	26076
	C6-W-391.22-32 054	63	32	72	30	61	46	54	1.33	71255	26077

Dimensions, mm

Note: Without adjustment screw.



Short shrink fit adapter – without gripper groove

For cylindrical tool shanks

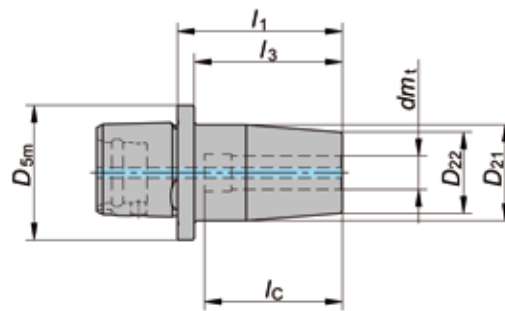

Coupling Size	Item No.	D _{5m}	dm _t	D ₂₁	D ₂₂	l _c	l ₁	l ₃	kg
C3	C3-W-391.19-06 048	32	6	24.5	20	36	48	42	0.20
	C3-W-391.19-08 048	32	8	24.5	20	36	48	42	0.19
	C3-W-391.19-10 048	32	10	27	22.5	41	48	42	0.21
	C3-W-391.19-12 048	32	12	27	22.5	46	48	42	0.20
C4	C4-W-391.19-06 049	40	6	24.5	20	36	49	43	0.26
	C4-W-391.19-08 049	40	8	24.5	20	36	49	43	0.26
	C4-W-391.19-10 049	40	10	28.5	24	41	49	43	0.30
	C4-W-391.19-12 049	40	12	28.5	24	46	49	43	0.28
	C4-W-391.19-14 049	40	14	31.5	27	46	49	43	0.33
	C4-W-391.19-16 054	40	16	32.3	27	49	54	48	0.33
C5	C5-W-391.19-06 050	50	6	24.5	20	36	50	44	0.38
	C5-W-391.19-08 050	50	8	24.5	20	36	50	44	0.37
	C5-W-391.19-10 050	50	10	28.5	24	41	50	44	0.42
	C5-W-391.19-12 050	50	12	28.5	24	46	50	44	0.40
	C5-W-391.19-14 050	50	14	31.5	27	46	50	44	0.43
	C5-W-391.19-16 055	50	16	32.3	27	49	55	49	0.45
C6	C6-W-391.19-06 052	63	6	24.5	20	36	52	44	0.61
	C6-W-391.19-08 052	63	8	24.5	20	36	52	44	0.60
	C6-W-391.19-10 052	63	10	28.5	24	41	52	44	0.65
	C6-W-391.19-12 052	63	12	28.5	24	46	52	44	0.63
	C6-W-391.19-14 052	63	14	31.5	27	46	52	44	0.66
	C6-W-391.19-16 057	63	16	32.3	27	49	57	49	0.68

Dimensions, mm

Note:
Without adjustment screw.

Note:

The tolerance of the cutting tool shank diameter must be h6 or better. The cylindrical tool shank should be cleaned and deburred before mounting into the adapter.

Shrink fit heating equipment

The shrink fit adapters depend upon applying heat to expand the adapter. When cooled, the adapter contracts to grip around the tool shank. Please check if your induction heating equipment can accept the special dimensions of the above short shrink fit adapters.

For guaranteed function, optimal tool performance, and for safe and easy handling of the clamping process, it is recommended that Bilz Power Clamp induction heating equipment for short adapters is used. It is required to follow the instruction from the induction heating equipment producer. Further information is available at www.bilz.com.

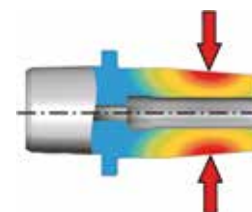

Short Adapter



Short combination mill adapter – without gripper groove

For side mills, face mills, or disk cutters

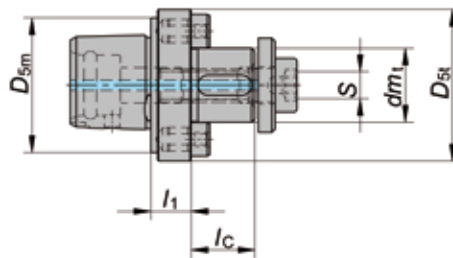

Coupling Size	Item No.	D _{5m}	dm _t	D _{5t}	l _c	l ₁	S	kg			
C3	C3-W-391.05-16 015	32	16	36	17	15	6	0.18	84130	84903	26075
	C3-W-391.05-22 019	32	22	45	19	19	8	0.31	84131	84904	26076
C4	C4-W-391.05-16 010	40	16	40	17	10	6	0.21	84130	84903	26075
	C4-W-391.05-22 012	40	22	45	19	12	8	0.31	84131	84904	26076
	C4-W-391.05-27 014	40	27	50	21	14	10	0.42	84132	84905	26077
C5	C5-W-391.05-22 012	50	22	50	19	12	8	0.42	84131	84904	26076
	C5-W-391.05-27 012	50	27	50	21	12	10	0.49	84132	84905	26077
	C5-W-391.05-32 018	50	32	63	24	18	14	0.79	84133	84906	26078
C6	C6-W-391.05-22 010	63	22	63	19	10	8	0.60	84131	84904	26076
	C6-W-391.05-27 011	63	27	63	21	11	10	0.70	84132	84905	26077
	C6-W-391.05-32 016	63	32	63	24	16	14	0.90	84133	84906	26078

Dimensions, mm

Delivery with the arbor clamping bolt without hole for coolant supply.

Note:

Universal design: key and drivers can be removed.

Arbor clamping bolt with coolant hole for internal coolant supply

Arbor Size		
16	84841	26075
22	84842	26076
27	84843	26077
32	84844	26078

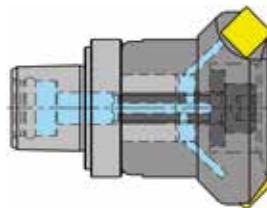



Cylindrical collets for short hydro high precision chuck adapter Slotted

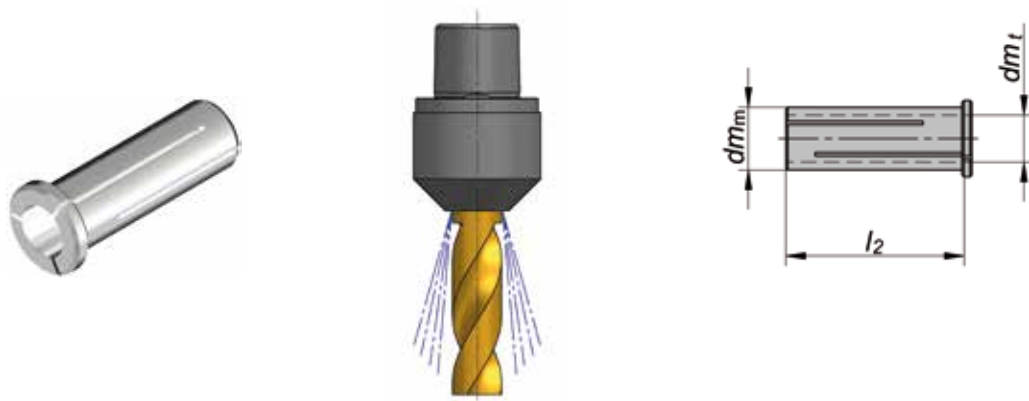

Collet Size	Item No.	dm_t	dm_m	l_2	Collet Size	Item No.	dm_t	dm_m	l_2	
12	244012002	2	12	38	20	244020002	2	20	50.5	
	244012003	3	12	38		244020003	3	20	50.5	
	244012004	4	12	38		244020004	4	20	50.5	
	244012005	5	12	38		244020005	5	20	50.5	
	244012006	6	12	38		244020006	6	20	50.5	
	244012007	7	12	38		244020007	7	20	50.5	
	244012008	8	12	38		244020008	8	20	50.5	
	244012009	9	12	38		244020009	9	20	50.5	
	244012010	10	12	38		244020010	10	20	50.5	
	16	244016002	2	16		45	25	244020012	12	20
244016003		3	16	45	244020014	14		20	50.5	
244016004		4	16	45	244020016	16		20	50.5	
244016005		5	16	45	244025003	3		25	56	
244016006		6	16	45	244025004	4		25	56	
244016007		7	16	45	244025005	5		25	56	
244016008		8	16	45	244025006	6		25	56	
244016009		9	16	45	244025007	7		25	56	
244016010		10	16	45	244025008	8		25	56	
244016012		12	16	45	244025009	9		25	56	
						244025010		10	25	56
						244025012		12	25	56
					244025014	14	25	56		
					244025016	16	25	56		
					244025018	18	25	56		
					244025020	20	25	56		
					244025022	22	25	56		

Dimensions, mm

Dimensions, mm



Cylindrical collets for short hydro high precision chuck adapter

Sealed



Collet Size	Item No.	dm _t	dm _m	l ₂	l ₃	Collet Size	Item No.	dm _t	dm _m	l ₂	l ₃	
12	244112003	3	12	40	29	20	244120003	3	20	50.5	17	
	244112004	4	12	40	29		244120004	4	20	50.5	17	
	244112005	5	12	40	30		244120005	5	20	50.5	17	
	244112006	6	12	40	36		244120006	6	20	50.5	26	
	244112007	7	12	40	37		244120007	7	20	50.5	26	
	244112008	8	12	40	37		244120008	8	20	50.5	26	
	244112009	9	12	40	37		244120009	9	20	50.5	26	
	244112010	10	12	40	40		244120010	10	20	50.5	31	
	16	244116003	3	16	47.5		20	244120012	12	20	50.5	35
		244116004	4	16	47.5		27	244120014	14	20	50.5	35
244116005		5	16	47.5	30	244120016	16	20	50.5	35		
244116006		6	16	47.5	36	25	244125003	3	25	56	29	
244116007		7	16	47.5	36		244125004	4	25	56	30	
244116008		8	16	47.5	36		244125005	5	25	56	30	
244116009		9	16	47.5	37		244125006	6	25	56	26	
244116010		10	16	47.5	39		244125007	7	25	56	37	
244116012		12	16	47.5	45		244125008	8	25	56	26	
244116014		14	16	47.5	45		244125009	9	25	56	38	
							244125010	10	25	56	31	
							244125012	12	25	56	34	
							244125014	14	25	56	35	
						244125016	16	25	56	37		
					244125018	18	25	56	37			
					244125020	20	25	56	38			

Dimensions, mm

Dimensions, mm

Wrench for dismounting cylindrical collets

Collet Size	
12 - 25	88895

Note:

l₃ = clamping length required to achieve the sealing effect.

Highest precision

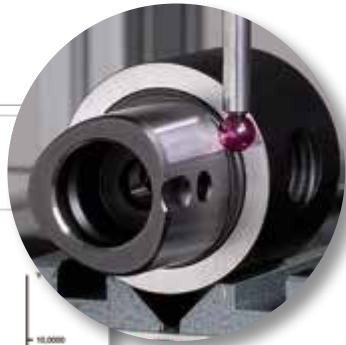
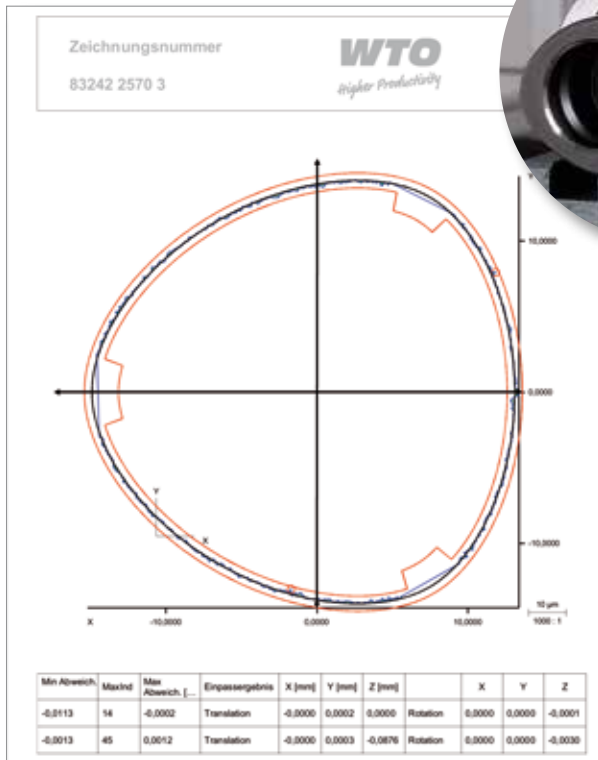

To guarantee the high precision of the interface WTO manufactures Coromant Capto® exactly with the same tolerances required by Sandvik Coromant.





WTO is worldwide the first licensee for toolholders with Coromant Capto® (since 1991).

The close cooperation with Sandvik Coromant since 1990 ensures WTO's know-how to manufacture Coromant Capto®.

WTO manufactures Coromant Capto® exactly according to the same strict manufacturing and inspection procedures as the original product of Sandvik Coromant.

Therefore a 100% compatibility of the interface can be guaranteed.

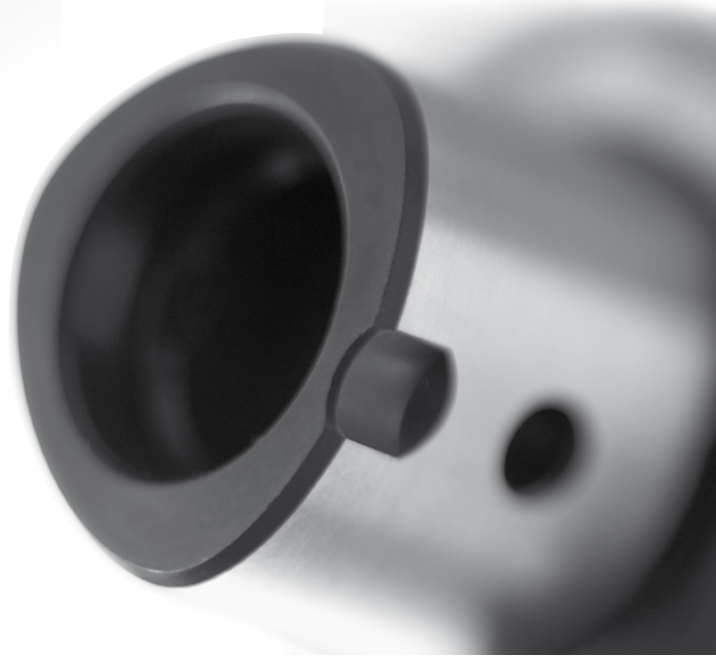

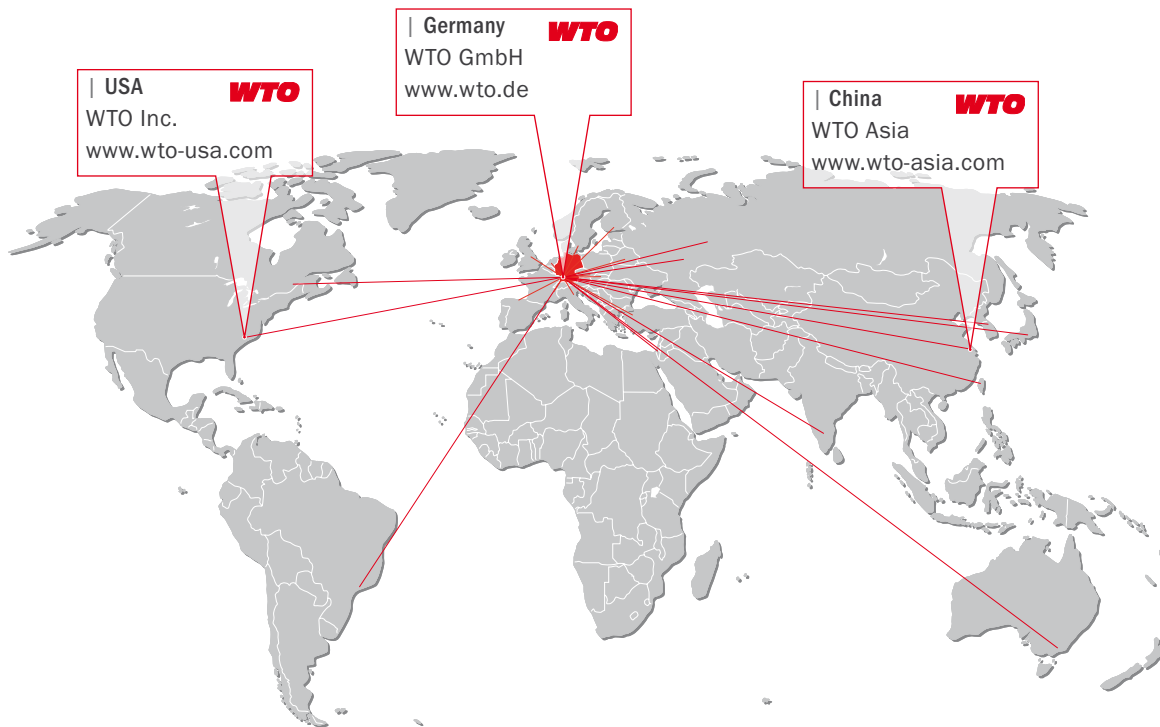

WTO GmbH
Auf der oberen Au 45
77797 Ohlsbach
Germany

WTO USA
13900 S Lakes Dr Ste F
Charlotte NC 28273-7119
USA

WTO Asia
Room 109-110, Building 2
No. 228 Banting Road
Jiuting Town,
Songjiang District
201615 Shanghai
China

Our distribution partners. Competence right there.

| **Australia**
Dimac Tooling Ltd.
sales@dimac.com.au

| **Finland**
Suomen Terästuonti Oy
myynti@stt.as

| **Korea**
WTO Office Korea
is.chon@wto-korea.com

| **Slovakia**
ALBA precision s.r.o.
albaprecision@albaprecision.sk

| **Belarus**
JSC "PMI Engineering"
tool@pmi.by

| **France**
Philippe Tagliafero
pta@wto.de

| **Mexico**
Workholding Engineering De México
info@wem.com.mx

| **Spain**
ITALMATIC, S.A.
italmatic@italmatic.es

| **Brazil**
TF2
tfdois@tfdois.com.br

| **Great Britain**
Cutwel Ltd.
sales@cutwel.net

| **Netherlands**
Toologic BeNeLux B.V.
info@toologic-benelux.nl

| **Sweden**
Komet Scandinavia AB
scandinavia@kometgroup.com

| **Canada**
Mittmann Industrial Inc.
info@mittmann.com

| **India**
A.H. Rao
ahr.rao@gmail.com

| **Norway**
Helge Karlsen Verktøy og Maskin AS
hkvm@hkvm.no

| **Switzerland**
Utilis AG
info@utilis.com

| **China**
Shanghai Gangde
wtocando@yahoo.com

| **Israel**
E.Y.A.R. Ltd.
yehoshua@eyar.co.il

| **Poland**
ARCO Andrzej Rudenko
info@arcotools.pl

| **Taiwan**
Kaiko Co., Ltd.
info@kaiko.com.tw

| **Czech Republic**
ALBA precision, spol. s.r.o.
info@albaprecision.cz

| **Italy**
Prymark srl
commerciale@prymark.it

| **Romania**
SC Elif Trading SRL
bulent.ozkan@eliftrading.com

| **Turkey**
MYK CNC MAKINA SAN. VE
huseyin.tatlidil@mykcnc.com.tr

| **Denmark**
Tool-part
cj@tool-part.dk

| **Japan**
NK Works Co. Ltd.
k_samba@nk-works.co.jp

| **Russia**
WTO Office Russia
office@wto-russia.com

| **Ukraine**
„LLC“ SPA Stankopromimport
info@phoenix-ua.com